



AS-950, AV-950 and AV-750

Venetian blinds

Innovative.



Innovative sun and weather protection

AS-950, AV-950 and AV-750 Compound metal venetian blinds

AS-950, AV-950 and AV-750 compound metal venetian blinds with 90 mm- or 70 mm-wide slats impress with a lift mechanism integrated into the side guidance. This eliminates the need for the slat holes and lift tapes found on conventional blinds.

In all models, the bottom rail is secured against being raised at any height, and against striking obstacles when closing.

Textured coating

The innovative textured coating used for the slats demonstrates significantly better colour retention and weather resistance than the conventional smooth coating. Dirt adhesion is substantially reduced and the slats are easy to clean.

Daylight use

The blind can be split into two or three sections with different slat inclines. Open slats in the upper section enable daylight to penetrate into the depths of the room, while closed slats in the lower section serve as glare protection for the window.

Range of colours

Choose from around 28 standard colours, including a range of IGP and metallic colours. You can also choose from more than a thousand RAL, NCS and IGP colours.

Automated convenience

Venetian blinds can be fitted with electric drives for greater ease of operation. In conjunction with the corresponding controller, this meets the Minergie standard.

Excellent materials

Weatherproof chrome steel slat hooks, metal guide bolts, Kevlar-reinforced turning cords and slats with textured coating all ensure that the blinds will last for a long time.

Improved dimming and easier cleaning

No lift tapes means that there is no need for holes in the slats. As a result, light can no longer penetrate through these holes, which provides significantly improved dimming. The lack of lift tapes makes the slats easier to clean.



Lock

All models are equipped with an automatic lock which prevents the bottom rail from being raised at any height, and unlocks automatically when the blind is raised.



Obstacle protection

If an obstacle is encountered (e.g. a vase or a chair), the bottom rail will stop automatically and readjust itself of its own accord when next raised.



Bottom rail

The bottom rail turns in the same way as the slats. Viewed from the outside when closed, the blind resembles the AS-900, AV-900 or AV-700 venetian blind. These designs can therefore be combined (e.g. ground floor with AS-950, upper floor with AS-900).



Metal guide bolts and chrome steel hooks

Metal guide bolts ensure durability and resistance to breakage. The weatherproof chrome steel hooks attaching the slats to the turning cords enable damaged slats to be subsequently replaced.

Installation on embrasure in recess

Bottom rail AV-950, mitre cut 15°

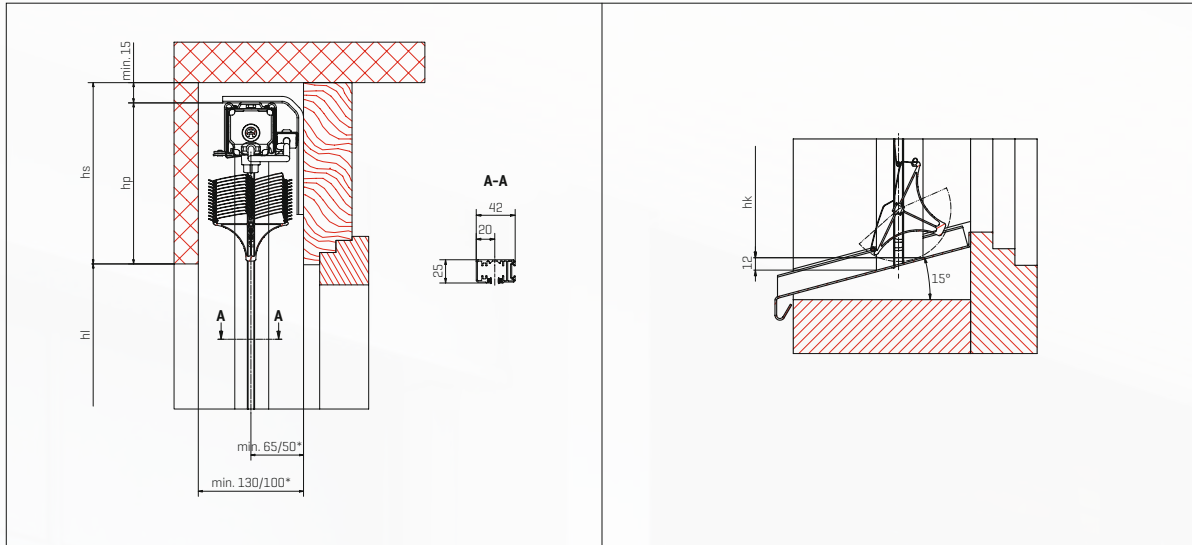

Self-supporting installation with cover panel type 1

Bottom rail AV-950, mitre cut 30°

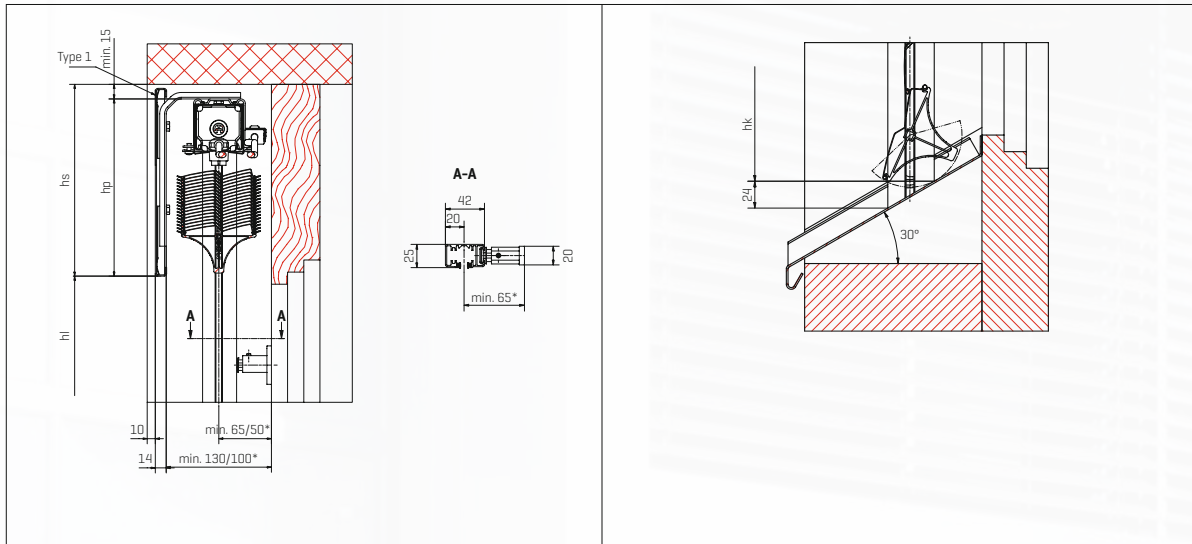

Installation on facade with cover panel type 8

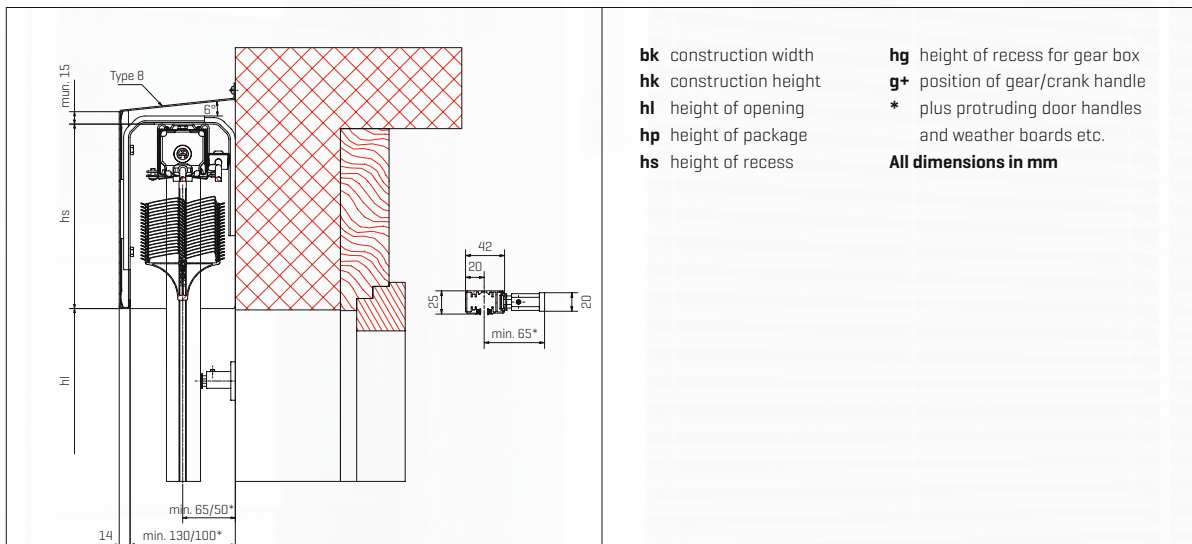

- bk** construction width
- hk** construction height
- hl** height of opening
- hp** height of package
- hs** height of recess
- hg** height of recess for gear box
- g+** position of gear/crank handle
- * plus protruding door handles and weather boards etc.

All dimensions in mm

Height of opening [hl]	Height of recess [hs] AS-950	Height of recess [hs] AV-950	Height of recess [hs] AV-750
to 1750 mm	245 mm	245 mm	235 mm
1751 to 2000 mm	260 mm	260 mm	260 mm
2001 to 2250 mm	275 mm	275 mm	290 mm
2251 to 2500 mm	290 mm	290 mm	310 mm
2501 to 2750 mm	305 mm	305 mm	330 mm
2751 to 3000 mm	320 mm	320 mm	350 mm
3001 to 3250 mm	335 mm	335 mm	370 mm
3251 to 3500 mm	350 mm	350 mm	395 mm
with cover panel	+ 20 mm	+ 20 mm	+ 20 mm
minimum	400 mm	400 mm	400 mm
maximum	3500 mm	3500 mm	3500 mm
Construction width [bk]			
min. with crank drive	400 mm	400 mm	400 mm
min. with electric drive	550 mm	550 mm	550 mm
maximum	3000 mm	3000 mm	3000 mm
Area [bk x hk]			
Single blinds			
max. with crank drive	5 m ²	5 m ²	5 m ²
max. with motor drive	6 m ²	6 m ²	6 m ²
Recess depth [ts]			
minimum	130 mm	130 mm	100 mm
Wind resistance class			
bk < 1500 mm	class 6	class 6	class 6
bk < 2000 mm	class 6	class 6	class 6
bk < 2500 mm	class 6	class 6	class 6
bk < 3000 mm	class 5	class 5	class 5

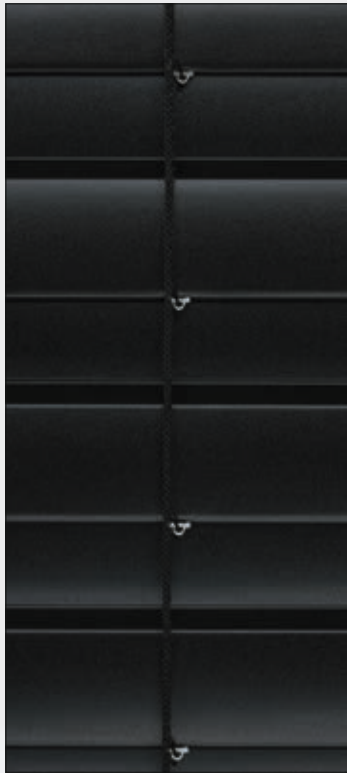

Lowering

In the standard model, the slats are lowered in the closed position.



End position

In the standard model, the slats are lowered in the end position. A short upward movement can be used to open them to the horizontal position.

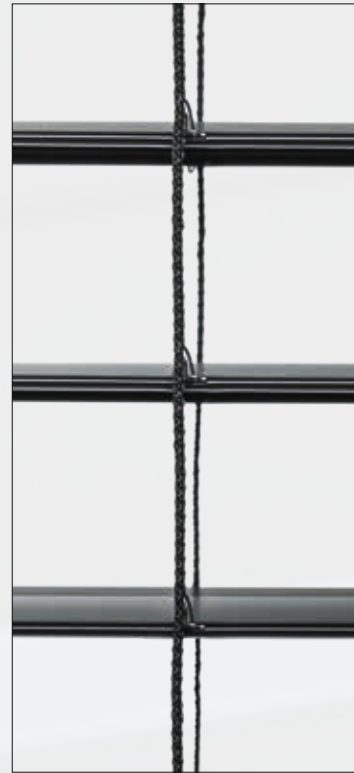

Raising

In both models, the blind is raised with the slats in the horizontal position. This ensures that the maximum amount of light can penetrate.

Development

Storenmaterial AG
www.stoma.ch



AS950.AV950.AV750.EN.2024

Sales

